



This manual is for reference and historical purposes, all rights reserved.

**This page is copyright© by M. Butkus, NJ.**

This page may not be sold or distributed without the expressed permission of the producer

I have no connection with any camera company

On-line camera manual library

This is the full text and images from the manual. This may take 3 full minutes for the PDF file to download.

**If you find this manual useful, how about a donation of \$3 to: M. Butkus, 29 Lake Ave., High Bridge, NJ 08829-1701 and send your e-mail address so I can thank you. Most other places would charge you \$7.50 for a electronic copy or \$18.00 for a hard to read Xerox copy.**

**This will allow me to continue to buy new manuals and pay their shipping costs.**

**It'll make you feel better, won't it?**

**If you use Pay Pal or wish to use your credit card,  
click on the secure site on my main page.**

**Canon**

**EOS**

**5000 / 5000<sub>QD</sub>**



English Edition  
**INSTRUCTIONS**

## **Thank you for purchasing this Canon product.**

Read these instructions carefully before using your camera. The instructions consist of the following six sections:

### **I. Preparations**

An explanation of the preparations you should carry out before beginning to take photographs.

### **II. Basic Operations**

An explanation of the basic ways of taking photographs.

### **III. Advanced Operations**

An explanation of different ways of taking photographs using the camera's various functions.

### **IV. Self-Timer Operation and Date Imprinting**

An explanation of how to use the self-timer and date imprinting functions.

### **V. Optional BP-8 AA Battery Pack**

An explanation of how to use the BP-8 AA Battery Pack

### **VI. Other Information**



An explanation of basic photographic terminology and a guide to available accessories.

After reading this instruction manual, retain it for future reference.

## Major Features

1. Light-weight and compact single lens reflex (SLR) camera.
2. A wide auto-focus/AIM\* system
  - \* AIM (Advanced Integrated Multi-Point Control)  
AIM is a system which automatically sets the optimum exposure or flash exposure at one of the three focusing points which achieved focus within the wide focus area.  
It allows anyone to take good photos just by composing the shot and pressing the shutter button.
3. A simple dial operation which allows you to take photographs exactly as you see them in the image zone.
4. Silent operation.

## Notes

- Your new EOS camera can be used with any Canon EF lens. These instructions include an explanation of how to mount EF lenses.
- In this instruction manual, the following symbols in note boxes have the following meanings:
  -  : Important notes to prevent malfunction or misoperation.
  -  : Camera operation notes you should know about.
  -  : Useful hints on camera operation or shooting.
- The (→ see page \_\_) mark indicates the page where there is more information. Please read the related information accordingly.
- In order to prevent faulty shots or camera malfunctions, please read the "Precautions" on page 6.







### IMPORTANT INFORMATION

This camera will give optimum performance together with specially designed Canon EF lenses, flash units and other Canon-brand accessories. The use of incompatible lenses or other accessories may result in unsatisfactory performance or damage to your camera. We therefore suggest the use of Canon EF lenses and accessories. Damage to your Canon camera as a result using incompatible products may void its warranty.

# Contents

	Precautions..... Immediate camera operation..... Nomenclature ..... External LCD panel .....
<b>I. PREPARATIONS</b>	Attaching the strap..... Battery installation and battery level check .....
<b>II. BASIC OPERATIONS</b>	Taking photographs on the full automatic setting ( <input type="checkbox"/> ) ..... AF auxiliary light..... Automatic flash firing..... Red-eye reduction..... Focusing off-center subjects .....
<b>III. ADVANCED OPERATIONS</b>	Shutter-priority AE ..... Flash photography..... Taking photographs with exposure set for center of viewfinder (partial metering).....
<b>IV. SELF-TIMER OPERATION AND DATE IMPRINTING</b>	Self-timer operation ..... Imprinting the date or time.....
<b>V. OPTIONAL BP-8 AA BATTERY PACK</b>	Nomenclature ..... Battery installation .....
<b>VI. OTHER INFORMATION</b>	Correct exposure..... AE ..... Shutter speed..... Aperture value..... Film speed (ISO number)..... Depth-of-field..... Troubleshooting tips ..... Functions usable in combination .....

..... 6	Viewfinder information.....	12
..... 8	Command dial.....	13
.....10		
.....12		
.....14	Mounting and removing lenses.....	16
	Shutter button and autofocus operations.....	17
.....14	Loading and removing film.....	18
	Using the portrait mode (  ).....	25
.....21	Using the landscape mode (  ).....	26
.....22	Using the close-up mode (  ).....	27
.....23	Using the sports mode (  ).....	28
.....23		
.....24		
.....29	Focusing on a subject in the center of the viewfinder	
.....33	(center focusing).....	37
	Bulb (long exposure) photography.....	38
.....36	Mid-roll film rewind.....	39
.....40	Changing the date and time.....	43
.....42	Changing the quartz date back's battery.....	44
.....45		
.....46		
.....48	Main accessories.....	53
.....48	Canon speedlite flash units.....	53
.....48	Remote switch RS-60E3.....	53
.....49	Eye-piece extender EP-EX15.....	53
.....49	Grip GR-80TP.....	54
.....50	Camera cases.....	54
.....51	Dioptric adjustment lenses.....	55
.....52	Major specifications.....	56
	A quick guide to function settings.....	59

# Precautions

---

## Camera Care

- (1) This camera is not resistant to water and must not be used in the rain or in water. If the camera accidentally gets wet, contact your nearest Canon service center as soon as possible. If a few water droplets fall on the camera, place it on a well-ventilated and stable surface and wipe it with a clean, dry cloth.
- (2) The camera can reach excessively high temperatures if exposed to direct sunlight, such as when left in a car during the day. Heat is a common source of camera problems, so please take care where you leave your camera.
- (3) The camera contains high-voltage electronic circuitry. On no account should you attempt to disassemble the camera yourself, as this can be dangerous.
- (4) Should dust accumulate on the lens or in the film compartment, use one of the commercially-available blower brushes to remove the dust. Never use cleaning materials containing organic solvents etc., on the camera body or lens. Should your camera become particularly dirty, contact your nearest Canon Service Center.
- (5) Remove the batteries if you do not expect to use the camera for an extended period. Store the camera in a well-ventilated, cool and dry place.
- (6) Do not store the camera in laboratories where chemicals are handled, as this can cause rust and corrosion. Similarly avoid placing the camera in drawers or other places where chemicals are stored.
- (7) If the camera has not been used for a long time, please check it carefully, particularly if taking it on an overseas trip or using it for some other special occasion. Either check the camera yourself or take it to your nearest Canon Service Center before using.

## The LCD Panel

The camera has a liquid crystal display (LCD). LCDs can become faint and difficult to read over time through normal usage. Should this happen, please take your camera to your nearest Canon Service Center to have the display replaced. (There is a charge for this service).

LCDs also respond more slowly at lower temperatures and can turn black at high temperatures of 60°C. If restored to a regular temperature, they will operate as normal.

### Lithium Batteries

Two CR123A/DL123A lithium batteries must first be correctly installed for the camera to operate. Please check the battery level in the following instances:

- (1) when you replace the batteries
- (2) when the camera has not been used for an extended period
- (3) when the shutter will not release
- (4) when you are taking photographs in very cold temperatures
- (5) when taking particularly important photographs
  - When loading batteries into the camera, check that the battery contacts are clean and avoid smearing them with finger-prints. This is to prevent poor contact and battery drain.
  - Batteries can be extremely dangerous if disassembled, recharged, exposed to high temperatures, shorted, or disposed of in fire.
  - While these batteries can serve well at low temperatures, the performance will drop off considerably below the freezing point. When using the camera in cold temperatures, keep a set of batteries warm in your pocket and install them just before you take your photographs.

### Using the Camera on Low Power

Even when the  symbol on the LCD panel blinks, correctly exposed photographs can still be taken when the shutter is released. However, auto film advance and automatic rewind may be impossible. Please replace the batteries with new ones.

### Electronic Contacts

When removing the lens, be sure not to damage the electronic contacts and the lens surface. Hold the lens with the contacts facing upwards.



# Immediate Camera Operation

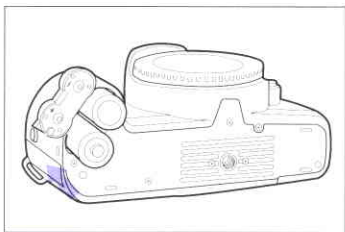

- 1** Install the batteries.  
Insert two lithium batteries (CR123A/  
DL123A) into the camera as indicated.

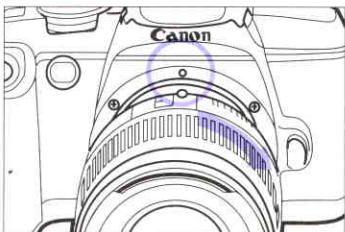

- 2** Attach the lens.  
Align the red marks on the camera and lens,  
and turn the lens clockwise until it stops and  
locks with a click.

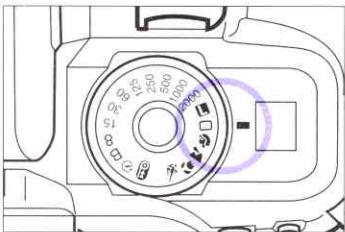

- 3** Set the command dial to .

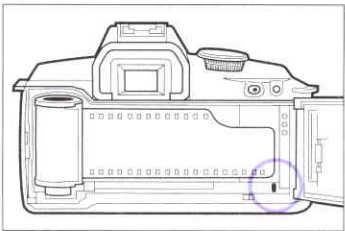

- 4** Load the film.  
Align the edge of the film leader with the  
orange mark and close the back cover until it  
clicks securely shut.
- The film will advance to the first frame.



- 5** Focus the subject.  
Compose the subject within the AF frame ( [ ] ) and press the shutter button halfway to focus.

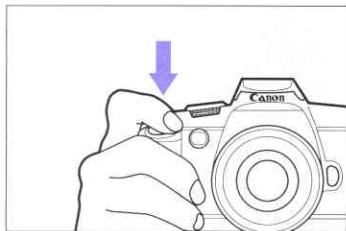

- 6** Take the photograph.  
Press the shutter button completely to take the picture.
- In dark or backlit conditions when the AE mark in the viewfinder blinks, use the flash (→ see page 33).

- 7** Unload the film.  
When the last frame on a roll of film has been taken, the film will rewind automatically. When complete, open the back cover and remove the film.

# Nomenclature

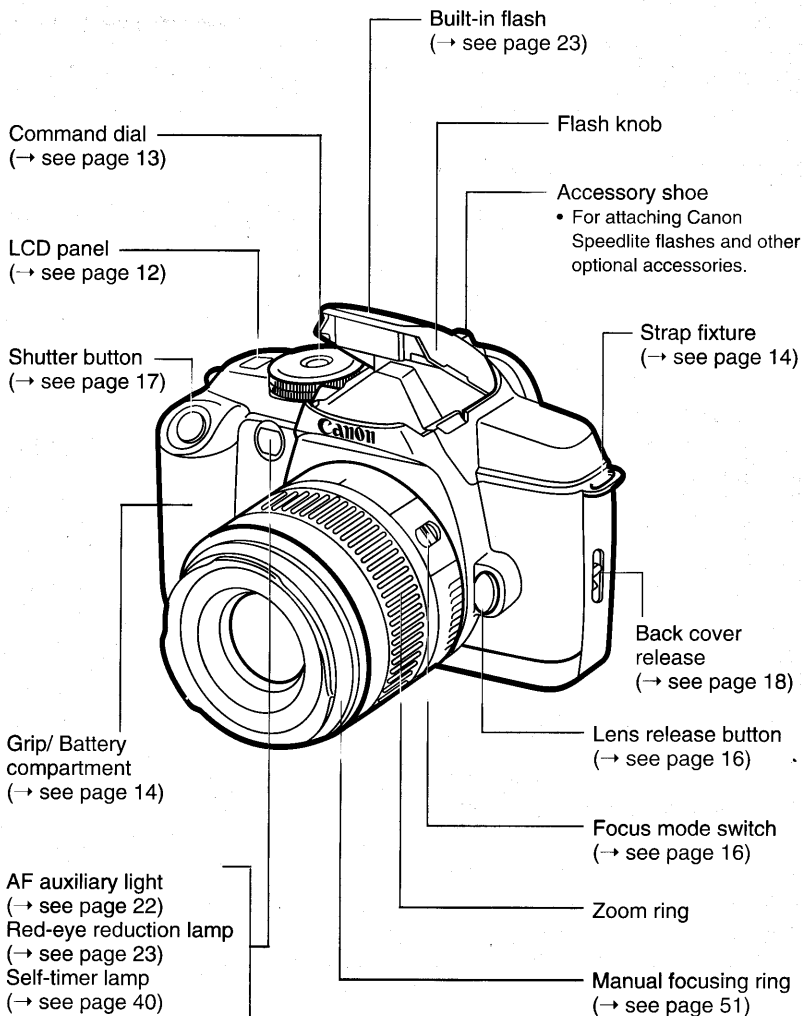

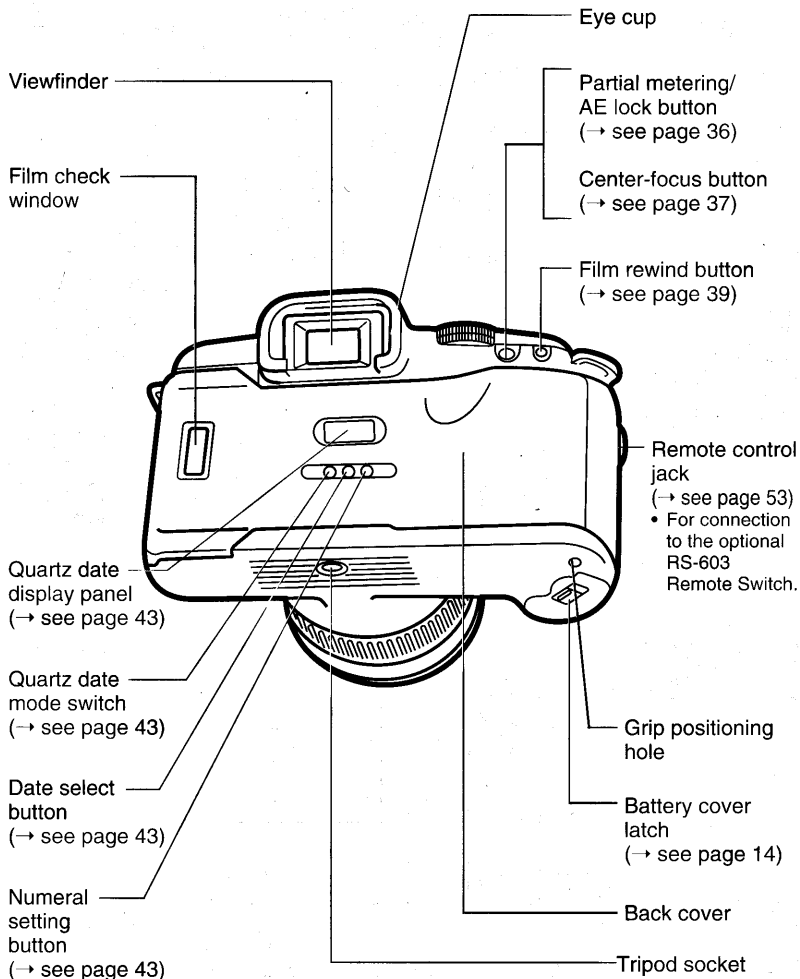

## Nomenclature

### Viewfinder Information

The figure below shows all the information that can be displayed.

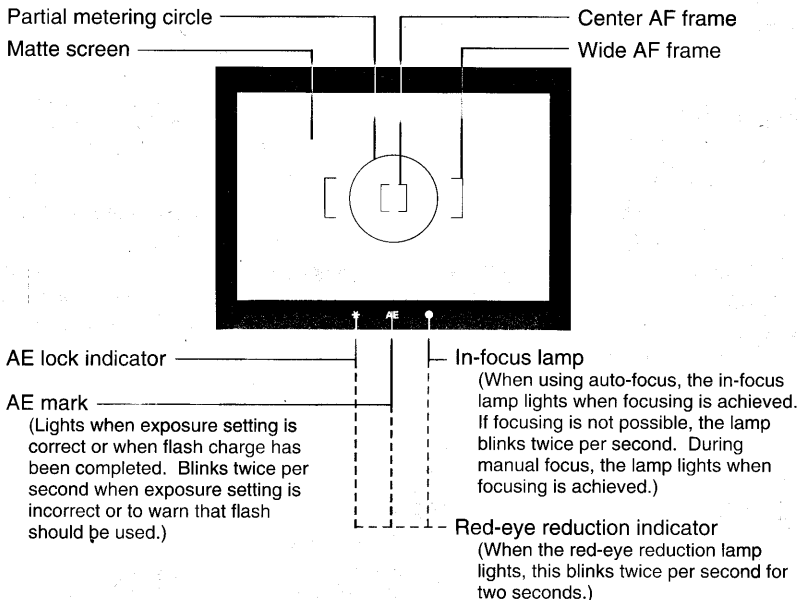

### External LCD Panel

The figure below shows all the information that can be displayed.

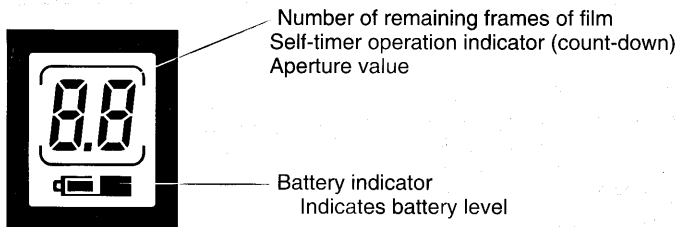

# Command Dial

The **L** lock (OFF) position is the reference point for the command dial's settings.

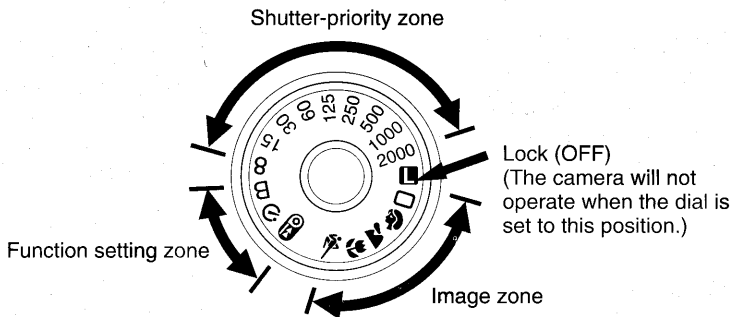

## Image Zone

- : Fully automatic (→ see page 21)
- P : Portrait (→ see page 25)
- L : Landscape (→ see page 26)
- C : Close-up (→ see page 27)
- S : Sports (→ see page 28)

- L : Lock

## Shutter-priority Zone

Sets the shutter speed in the shutter-priority AE mode.

The 2000 to 8 numerals correspond to speeds ranging from 1/2000th of a second to 1/8th of a second.

## Function Setting Zone

- B : Bulb (→ see page 38)
- 15 : Self-timer (→ see page 40)
- A : Mid-roll film rewind (→ see page 39)



When not using the camera set the command dial to **L**. Make sure the shutter button is not depressed inadvertently by any object in a camera bag, etc. A depressed shutter button will drain the batteries.

# I. PREPARATIONS

An explanation of preparations which must be carried out before taking photographs and of the operation of the shutter button.

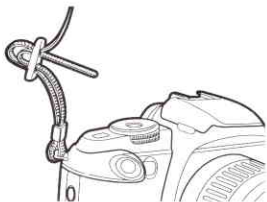

## Attaching the Strap

Thread the ends of the neckstrap through the strap fixture as shown. Before using, tug the strap to make sure that it is firmly secured to the fixture.

## Battery Installation and Battery Level Check

### Battery Installation

The camera uses two lithium batteries (CR123A/DL123A).

- If you have the BP-8 AA Battery Pack, please refer to page 45.

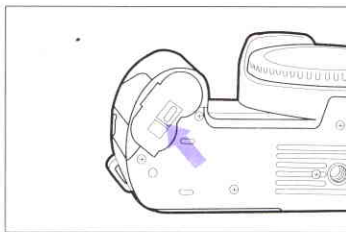

- 1 Slide the battery cover latch in the direction indicated to open the battery cover.

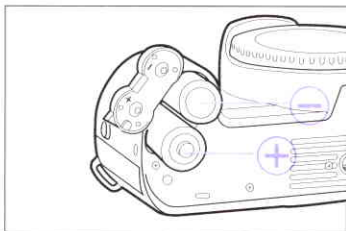

- 2 Insert the batteries with the + and - terminals pointing in the correct direction as indicated on the battery cover.

- 3 Close the battery cover.

## Checking the Battery Level

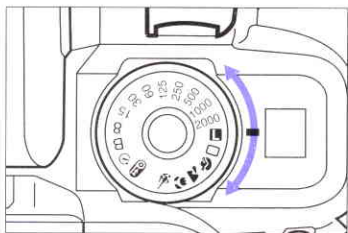

- 1 Release the lock by turning the command dial to a setting in the image zone or shutter-priority zone.

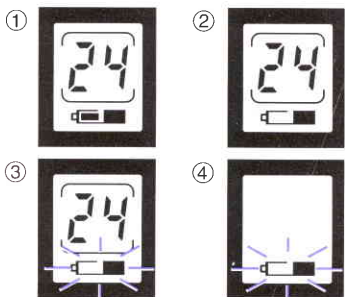

- 2 The battery indicator will be displayed on the LCD panel. The battery indicator variations indicate the following:

- ① : The battery power is sufficient.
  - ② : Battery power is low. Please have new batteries ready.
  - ③ : Replace both batteries with new ones.
  - ④ : Please see page 7.
- The command dial lock must be released before a battery check can be carried out.

- Service life of two lithium CR123A/DL123A batteries (number of rolls of film that can be taken).

Temperature	Without Flash	Half with Flash	With Flash
Normal (+20 °C)	110 Rolls	45 Rolls	23 Rolls
Low (-10 °C)	75 Rolls	30 Rolls	15 Rolls

\* Tests are based on new batteries, using the EF35-80mm f/4.0-5.6 III Lens and 24-exp. film. Data is based on Canon's Standard Test Method.

\* The number of rolls will be reduced for autofocus or filmless camera operations.



- If nothing is displayed on the LCD panel, check to see if the batteries are inserted upside down. Re-insert the batteries the correct way up.
- Always check the battery level before using the camera.
- Remember that batteries can sometimes be difficult to obtain in certain areas. Be sure to have an adequate supply when traveling overseas or when you expect to take a large number of photographs.



# Mounting and Removing Lenses

## Mounting a Lens

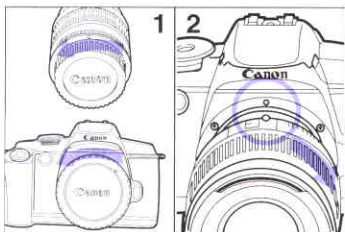

**1** Remove the rear lens cap and the body cap by turning them as shown by the arrow.

**2** Align the red marks on the lens and camera, and turn the lens in the direction of the arrow until it clicks.

**3** Set the focus mode switch on the lens to AF.

- If the switch is set to M, autofocus can not be used.
- When using autofocus, do not touch the rotating part of the lens.

**4** Remove the front lens cap.

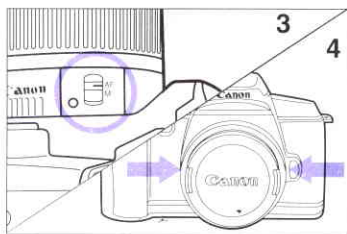

## Removing the Lens

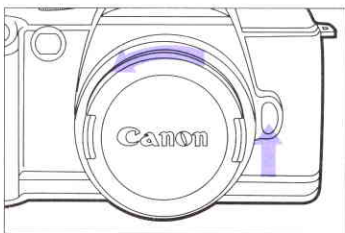

To remove the lens, press and hold down the lens release button and turn the lens as shown by the arrow until it stops.

# Shutter Button and Autofocus Operations

The EOS shutter button can be pressed halfway or all the way. The shutter button operates as follows.

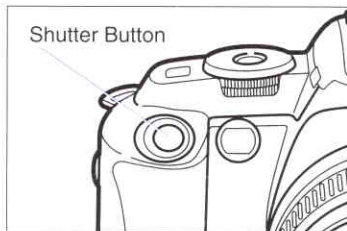

## Pressing the Shutter Button Halfway

- This initiates auto-focusing (AF). When focusing is achieved, a green light in the viewfinder (the focus lamp) lights up.
- At the same time, the shutter speed and aperture combination (exposure setting) is set. The AE mark in the viewfinder lights up and the aperture value is displayed on the LCD panel.

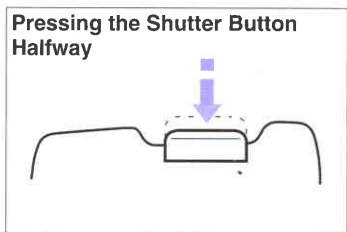

## Pressing the Shutter Button Completely

- This releases the shutter to take the picture and the film advances by one frame.

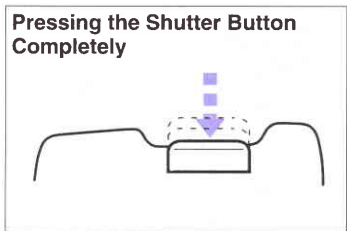

If the shutter speed is slow, blurred pictures may result due to camera shake. In order to obtain sharp photographs, please note the following three points:

- Avoid moving the camera while taking a photograph.
- Always hold the shutter button at the half-way point before taking photographs.
- Use a fast-enough shutter speed or use a tripod when using a slow shutter speed.

# Loading and Removing Film

## How to Load Film

When a roll of film is loaded, it is wound completely on the take-up spool. Then as each photograph is taken, the film rewinds into the cartridge frame by frame. The number of frames remaining on the roll of film is continually displayed.

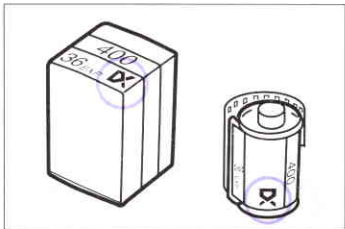

Please use DX-coded film, as the camera uses this to automatically detect and set the film speed. Films with a speed ranging from ISO 25 to 5000 may be used.

- 1 Release the command dial lock by setting to any position other than L.
- 2 Open the back cover by raising the back cover release.
- 3 Tilt the film cartridge as shown in the diagram to insert.

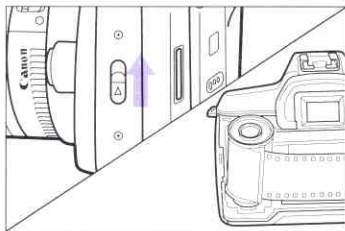

Infra-red film cannot be used.

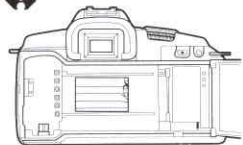

The shutter curtain is an extremely high-precision mechanism and must never be touched. When loading film, be very careful not to allow your fingers or the film to come into contact with the shutter curtain. Otherwise, the shutter curtain may be damaged or bent.

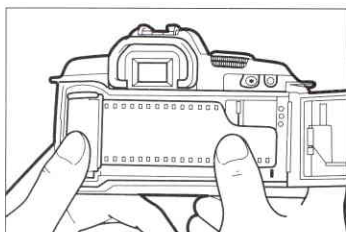

### 4 Align the edge of the film leader with the orange mark.

- To ensure that the film lies flat, press lightly on the film cartridge.
- If too much film is protruding, rewind the film cartridge slightly.

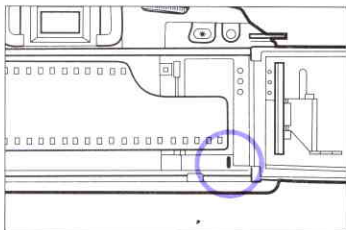

### 5 Make sure the film is aligned with the orange mark before closing the back cover.

The film will then begin to advance, and the number of available frames will begin to increase. When this is completed, you will hear sound like that of the shutter release, and the number of available frames will appear on the LCD panel.

- If the number of available frames does not appear, this means that the film has not been loaded correctly. Re-load the film correctly.

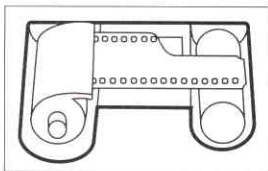

Correctly set

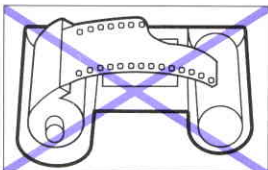

Incorrectly set

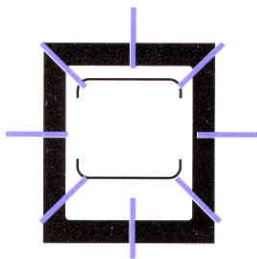

## I. PREPARATIONS

---

### Removing the Film



After the last frame on the film is taken, the film will automatically begin rewinding.

When the film has finished rewinding, **00** will appear on the LCD panel. After checking the display, open the back cover and remove the film cartridge.

To rewind the film in mid-roll, see page 39.

## II. BASIC OPERATIONS

For simple, basic operation, use the image zone settings on the command dial. The camera then takes over, setting everything automatically for your photograph. The various automatic settings possible are shown on page 52 in the section "Functions Usable in Combination". Note that not all combinations are possible.

### Fully Automatic Mode (□)

Taking photographs in the fully automatic mode allows you to take shots of all kinds of subjects with no fuss. As long as the subject is covered by the AF frame, anyone can obtain good results with ease.

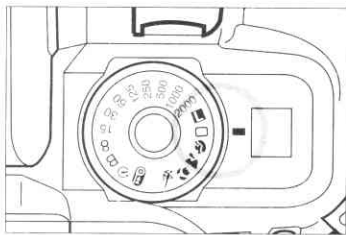

1 Set the command dial to □.



2 Look through the viewfinder and position the Wide AF Frame on the subject.

- If you wish to focus an off-center subject outside the Wide AF Frame, see the section "Focusing Off-Center Subjects" on page 24.

Wide AF Frame

## II. BASIC OPERATIONS

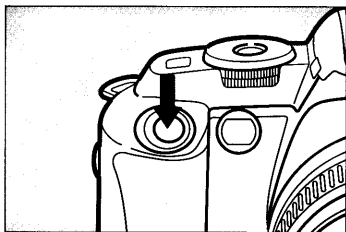

**3** Press the shutter button halfway. The subject is focused, and the shutter speed and aperture are set.

- A green lamp in the viewfinder (focus lamp) lights up.
- The aperture value is displayed on the LCD panel.

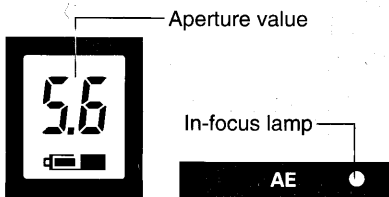

**4** Press the shutter button all the way to take the picture.



### • **Blinking AE Indicator (camera shake warning)**

If a slow shutter speed in the image zone may result in camera shake, the AE mark in the viewfinder will blink (the aperture value displayed on the LCD panel will not blink). If the AE indicator blinks, hold the camera steady and take care when pressing the shutter. The use of a tripod is recommended (even with a tripod, the AE mark will continue blinking.)

### • **Blinking in-focus lamp**

When the in-focus lamp blinks, the shutter cannot be released. Please see page 51.

## The AF Auxiliary Light Emitter

When focusing conditions are difficult, the AF auxiliary light emitter turns on automatically to illuminate the subject, making focusing easier.

### Automatic Flash Firing

If the AE indicator in the viewfinder blinks under dark or back-lit conditions, please use the flash (see page 33). The flash will fire automatically.

Automatic flash firing will function when an image zone setting is set.

### Red-eye Reduction

In photographs of people taken with flash, the subject's eyes may appear red. This is due to light from the flash reflected from the person's eyes. This phenomena is called "red-eye." For flash shots when red-eye is likely to occur, the red-eye reduction lamp lights automatically and momentarily causes the person's pupils to contract, thereby reducing the chance of red-eye. The red-eye reduction function operates automatically for shots taken in the fully automatic (□) and portrait modes (👤).

When the shutter button is pressed halfway, the indicators in the viewfinder will blink for 2 seconds to indicate that the red-eye reduction lamp turned on.



When the shutter button is pressed halfway until the indicators in the viewfinder stops blinking and reverts to normal, press the shutter button to take the photograph.



- The effectiveness of red-eye reduction may vary depending on the person.
- Red-eye reduction will not work unless the person(s) to be photographed looks at the red-eye reduction lamp.

Tell the person(s) to look at the red-eye reduction lamp before taking the picture.

To reduce red-eye, the following measures will also help:

- Take the photo under well-lit conditions.
- Move closer to the person(s) to be photographed.



## II. BASIC OPERATIONS

### Focusing Off-Center Subjects

When taking photographs of off-center subjects outside the wide AF frame, proceed as follows. This method is called focus lock photography.



- 1 Position the AF frame on the subject and press the shutter button halfway.



- 2 While keeping the shutter button pressed halfway, recompose the picture.
- 3 Press the shutter button all the way to take the picture.

## Using the Portrait Mode ( )



Use this setting when you wish to take a photograph with the subject in the foreground clearly emphasized against a blurred background.

- By pressing holding down the shutter button, continuous shooting is possible.
- If the subject is dark or in back-lit conditions and the AE indicator in the viewfinder blinks, please use the flash. (See page 33)

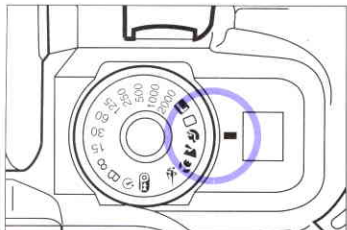

Set the command dial to .

The picture-taking procedure is the same as with the fully automatic mode. (See page 21)



- If the subject's head and shoulders fill up most of the center of the viewfinder, an effective background blur can be achieved. Background blur will improve as the subject moves farther away from the background.
- A more effective background blur can be achieved with a telephoto lens. If it is a zoom lens, set the lens to the telephoto setting (80mm in the case of a 35-80mm lens).



For expansive landscapes, sunset shots and night-time photographs, use the landscape mode.

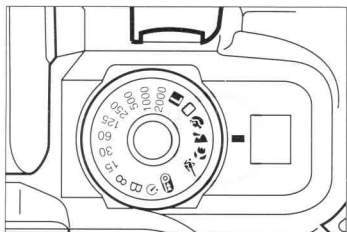

Set the command dial to .

The picture-taking procedure is the same as with the fully automatic mode. (See page 21)



- When using a zoom lens, use the wide-angle setting (35 mm in the case of a 35-80mm lens). This will create a feeling of expansiveness and add depth to your photograph.



- When you set the command dial to  with the built-in flash pulled-up, press the flash gently down until it retracts. The picture may not turn out the way you want it if the flash is on.
- If the AE indicator blinks, the shutter speed setting is slow and camera shake may cause a blurred picture. Be sure to hold the camera steady and press the shutter button gently. Use of a tripod is recommended (even with a tripod, the AE mark will continue blinking).

## Using the Close-up Mode ( )

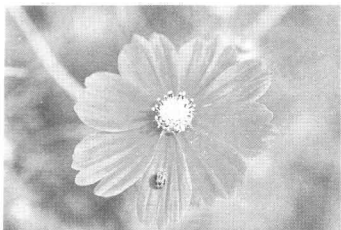

Use the lens built-in macro feature for close-up photography of plants and insects.

- Under dark or back-lit conditions when the AE indicator in the viewfinder blinks, please use the flash. (See page 33)

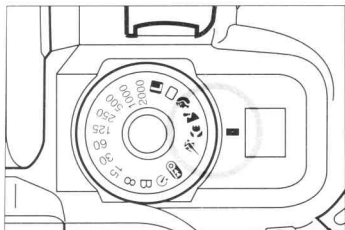

Set the command dial to .

The picture-taking procedure is the same as with the fully automatic mode. (See page 21)



- Get as close to the subject as your lens permits.
- With a zoom lens, you can achieve a higher minimum focusing distance magnification by setting the lens to telephoto.
- For basic macro photography we recommend Canon's macro lenses, and for advanced macro photography, we recommend you use Canon's macro lenses and the ML-3 macro ring light.



Use this setting when you wish to freeze fast-moving subjects in sports, etc.

- For continuous shooting, press and hold down the shutter button.

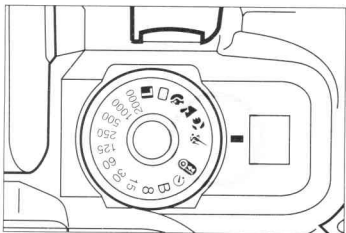

Set the command dial to .

The picture-taking procedure is the same as with the fully automatic mode. (See page 21)



- ISO 400 or faster films are recommended.
- Telephoto lenses such as the EF80-200mm F4.5 - 5.6 or the EF75 - 300mm F4 - 5.6, etc., are also recommended.



- When you set the command dial to  with the built-in flash pulled-up, press the flash gently down until it retracts. The picture may not turn out the way you want it if the flash is on.
- If the AE indicator blinks, the shutter speed setting is slow and camera shake may cause a blurred picture. Be sure to hold the camera steady and press the shutter button gently. Use of a tripod is recommended (even with a tripod, the AE mark will continue blinking).

### III. ADVANCED OPERATIONS

The shutter-priority zone settings on the command dial can be used for various advanced operations.

#### Shutter-priority AE

#### To Portray Moving Subjects

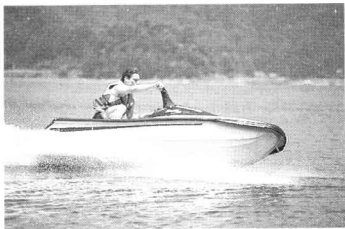

Fast shutter speed

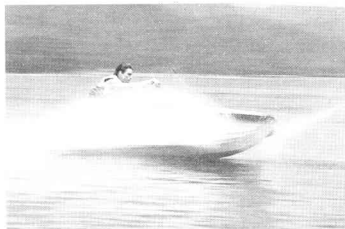

Slow shutter speed

In the shutter-priority zone, you set the shutter speed and the camera automatically sets the aperture to obtain a suitable exposure. This is called shutter-priority AE.

Faster shutter speeds allow you to freeze moving subjects, while with slower shutter speeds blur the subject with a feeling of motion.

- For continuous shooting, press and hold down the shutter button.



If you set the shutter speed at 1/15 sec you can take pictures of your television screen.

- When taking a photograph of a TV screen, be sure to hold the camera very steady or use a tripod.

### III. ADVANCED OPERATIONS

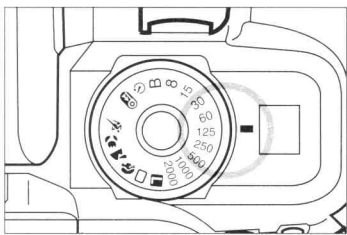

- 1 Turn the command dial and set the desired shutter speed.

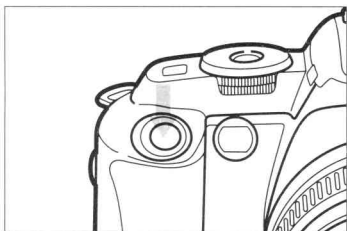

- 2 Press the shutter button halfway to focus the subject.
  - The aperture value will be indicated on the LCD panel.



- 3 Check that the AE indicator and the in-focus lamp in the viewfinder are lit, then take the photograph.



If the AE indicator in the viewfinder blinks, press the shutter button halfway and check the aperture value on the LCD panel.

- If the aperture value on the LCD panel blinks when the camera is set to the smallest aperture value (i.e. maximum aperture) of the lens, the scene is too dark. Should this happen, turn the command dial and lower the shutter speed until the AE indicator stops blinking. Check that the shutter speed will not result in a blurred picture due to camera shake.
- If the aperture value on the LCD panel blinks when the camera is set to the largest aperture value (i.e. minimum aperture) of the lens, the scene is too bright. Should this happen, turn the command dial and increase the shutter speed until the AE indicator stops blinking.





#### Changing the Depth of Field



Larger aperture value  
(smaller aperture diameter)



Smaller aperture value  
(larger aperture diameter)

If the shutter speed is changed, the aperture value will automatically change accordingly. The slower the shutter speed, the larger the aperture value (i.e. the smaller the aperture diameter) will be. The faster the shutter speed, the smaller the aperture value (i.e. the larger the aperture diameter) will be. In this way, you can change the depth of field.

A larger aperture value gives a greater depth of field and is suitable for expansive landscapes, where everything from nearby objects to background details are sharply in focus.

With a smaller aperture value, the depth of field is shallower, and this is ideal for beautiful portrait shots set off against a blurred background.

- For information on aperture values refer to page 49.



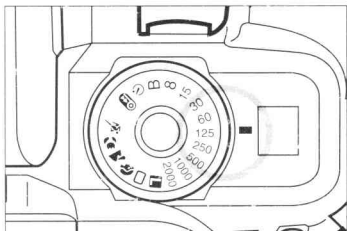

- 1 Set any shutter speed with the command dial.

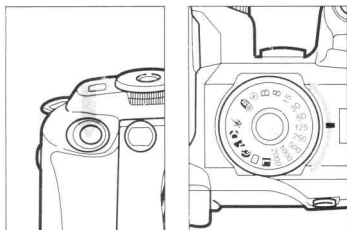

- 2 Press the shutter button halfway and turn the command dial to change the shutter speed until the desired aperture value is displayed on LCD panel.

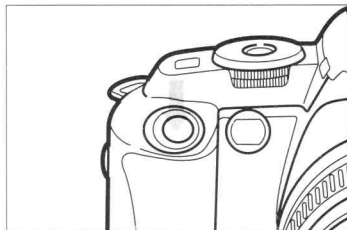

- 3 Press the shutter button halfway to focus the subject.
  - The aperture value will be indicated on the LCD panel.



- 4 Check that the AE indicator in the viewfinder is lit, then take the photograph.

AE

# Flash Photography



When using an image zone setting, use the flash if the AE indicator in the viewfinder blinks. When the flash is pulled up, it will turn on and fire automatically under low-light or back-lit conditions.

The flash will fire for all shots taken in the shutter-priority zone.

The flash can be used not just for low-light conditions, but also when the subject is heavily shaded or when you want to produce a catch-light in the people's eyes.

When the flash is used, the shutter speed will automatically be set at or below 1/90 sec.

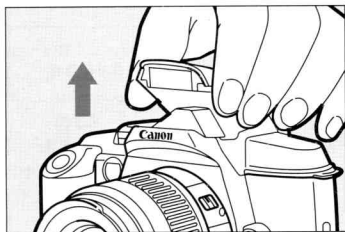

**1** Grasp the flash knob and raise the flash head gently.

- To retract the flash, push it down gently.

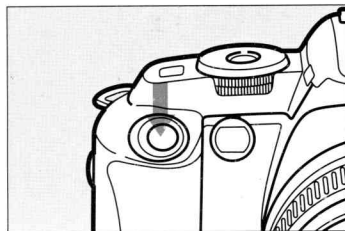

**2** Press the shutter button halfway to focus the subject.

**3** Check that the AE indicator in the viewfinder is lit before taking the photograph.

AE



### III. ADVANCED OPERATIONS



- If you use the flash at a camera-to-subject distance of one meter or closer, vignetting may occur. Back off to more than 1 meter from the subject to take flash photographs.
- A hood attached to the lens while taking photographs using the built-in flash can obstruct the light from the flash and cause vignetting. When using the built-in flash, always remove the hood from the lens.
- The following lenses can cause vignetting with the built-in flash. When using the following lenses for flash photography, we recommend using a dedicated external flash unit.
  - Large-diameter lenses such as the EF20-35mm f2.8L and the EF28-70mm f2.8L.
  - Super-telephoto lenses such as the EF300mm f2.8L and the EF600mm f4L.
- The built-in flash and an external flash cannot be used together.
- The built-in flash cannot be used when an external flash or the accessory shoe cover is attached to the accessory shoe.
- Before attaching an external flash, retract the built-in flash.

#### Flash Range

(with the EF35-80mm f4.0-5.6 III)

ISO	35 mm		80 mm	
	Negative Film	Slide Film	Negative Film	Slide Film
100	1 - 3.8 m 3.3 - 12.5 ft.	1 - 2.7 m 3.3 - 8.9 ft.	1 - 3 m 3.3 - 9.8 ft.	1 - 2.1 m 3.3 - 6.9 ft.
400	1 - 7.6 m 3.3 - 25 ft.	1 - 5.3 m 3.3 - 17.4 ft.	1 - 6 m 3.3 - 19.7 ft.	1 - 4.3 m 3.3 - 14.1 ft.

### III. ADVANCED OPERATIONS

#### Exposure Display Information When Using the Flash

Shooting Mode	Warning Display	Condition	Remarks
Shutter-priority AE	The maximum aperture value for the lens being used blinks.	The background is overexposed.	The subject is correctly exposed.

#### Shutter Synchronizing Speed and Aperture Value When Using the Flash

Shooting Mode	Shutter speed	Aperture value
Shutter-priority AE Zone	Manually set to any desired shutter speed of 1/90 sec. or slower*.	Aperture value is automatically set in relation to the set shutter speed and existing light.

\* If the shutter speed is set faster than 1/90 sec., the camera will automatically set it to 1/90 sec.

## Taking Photographs with Exposure Set for Center of Viewfinder (Partial Metering)

When there is a sharp difference in light levels between the subject and the background, it is possible to take the shot with the metering set for the center area of the viewfinder (areas covered by the center metering mark), without influence from the background. This is called partial metering. Partial metering operation locks the exposure (AE lock) at the same time as focusing the subject using the center focusing point (for information on center-priority range see page 37).

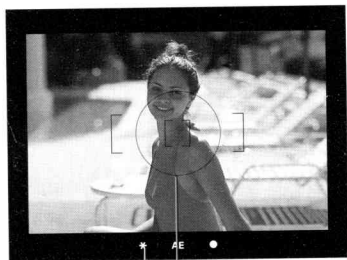

① Partial metering circle

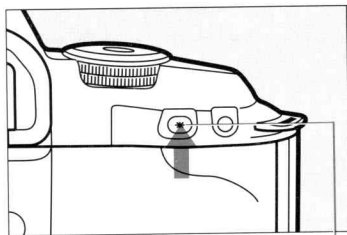

Partial metering/ AE lock button



- 1 With the command dial, set the desired shutter speed in the shutter-priority AE zone.
- 2 Look through the viewfinder and position the wide AF frame over the subject. Press the shutter button halfway to focus.
- 3 Position the partial metering circle over the subject requiring light compensation and press the partial metering/AE lock button.

- “\*” appears in the viewfinder to indicate that partial metering is locked ①.
- When \* appears and the shutter button is pressed halfway, the partial metering button may be released without the exposure setting changing (exposure set AE lock).

- 4 After checking the composition, press the shutter button fully to take the photograph.



If there is any obstruction in front of the subject it can be difficult to focus with the AF wide frame, so it may be better to use the center focusing frame (see page 37). Using the center focusing frame will activate partial metering at the same time.

## Focusing on a Subject in the Center of the Viewfinder (Center Focusing)

The example below shows a common type of photograph where the wide AF frame will result in the flowers coming into focus, while the main subject (the person) at the center becomes blurred. In a situation like this, the photograph can be taken with the person at the center in focus by using the center AF frame in the middle of the viewfinder. This is called center focusing. This function can also be used in close-up photography when you wish to focus on a particular part of the subject.



Center AF frame

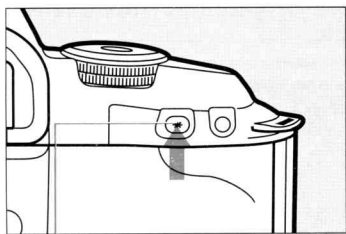

Partial metering/ Center focus button



- 1 With the command dial, set the desired shutter speed in the shutter-priority AE zone.
- 2 Look through the viewfinder and check that the center AF frame is positioned on the subject you wish to focus.
- 3 Hold down the center focus button and press the shutter button halfway.
  - This will set center focus at the same time as setting the partial metering (exposure set/AE lock).
- 4 Check that the subject is in focus and compose the picture. Press the shutter button fully to take the photograph.

# Bulb (Long Exposure) Photography

In bulb photography, the shutter remains open as long as the shutter button is held down. When you release the shutter button, the shutter will close. Use this function when long exposures are required, such as when shooting night shots or fireworks. Make sure the camera does not move during exposure by using a tripod or placing it on some other steady surface. Bulb photography can be made easier by using the release lock function on the optional RS-60E3 remote switch.

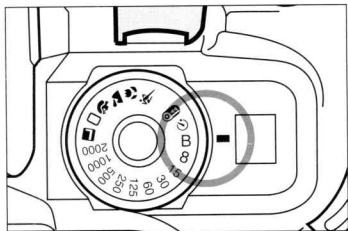

- 1 Set the command dial to **B**.

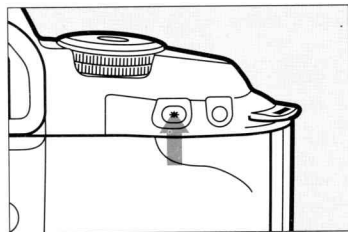

- 2 Look at the LCD panel, press the partial metering button and set the aperture value to the desired setting.

- The aperture value will change each time the partial metering button is pressed.

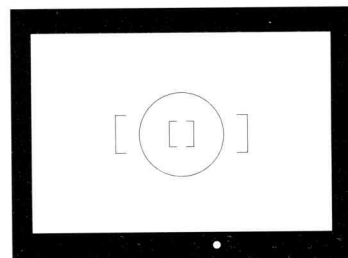



- 3 Compose the photograph and take the picture. The shutter will remain open as long as the shutter button is held down.

- With new batteries, the bulb exposure can be as long as about six hours.
- When taking bulb exposures, the AE indicator in the viewfinder will not light or blink. When using the flash, however, the AE indicator will light to indicate that the flash has completed charging.

# Mid-Roll Film Rewind

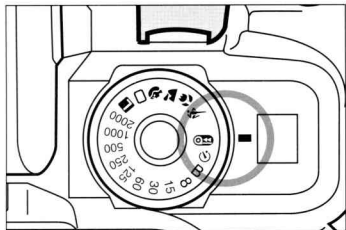
If you want to remove the film from the camera before the end of the roll, follow the procedure below.



- 1** Set the command dial to .

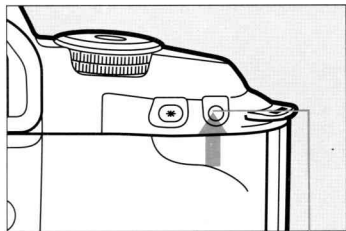

Film rewind button

- 2** Press and hold down the film rewind button for at least one second.

- The film will begin to rewind and, as soon as winding is completed, you will hear a sound like that of the shutter release. The figures  will appear on the LCD panel.

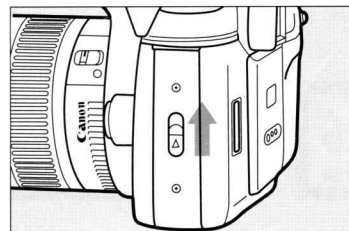

- 3** Open the back cover and remove the film.



If you remove the film before the end of the roll without pressing the film rewind button, the next film loaded will continue to wind back into the film cartridge. To prevent this, close the back cover once and press the shutter button down fully before loading the new film.





## IV. SELF-TIMER OPERATION AND DATE IMPRINTING

You can take photograph with the self-timer and imprint the date or time.

### Self-timer Operation

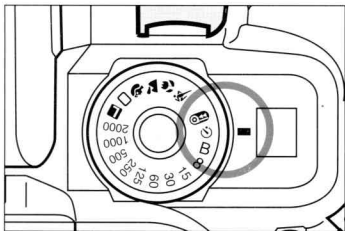
The self-timer allows the person releasing the shutter to also be in the photograph. Use a tripod when taking self-timer shots.



- 1 Set the command dial to .

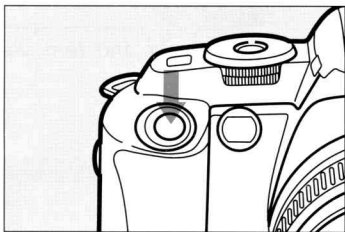

- 2 Press the shutter button halfway to focus.



## IV. SELF-TIMER OPERATION AND DATE IMPRINTING

---

- 3** Press the shutter button down fully while looking through the viewfinder. The shutter will be released about 10 seconds after the shutter button is pressed fully.

The red-eye reduction lamp will blink and light as follows until the shutter is released:

For first eight seconds ...lamp blinks twice per second

For final two seconds.....lights on

- The 10-second self-timer countdown to shutter release is displayed on the LCD panel.



- Standing in front of the camera when pressing the shutter button can result in out-of-focus pictures.
- To cancel the self-timer while it is operating, set the command dial to any position other than .

When operating the self-timer, exposure settings will be the same as when camera is set to fully automatic .

# Imprinting the Date or Time

If your camera has the Quartz Date back, please read the following section.

The camera comes with an auto date function which includes an auto date calendar up to the year 2019. The date or the time can be imprinted onto your photographs as you take them. The year, month, day and time can be displayed on the auto date LCD display panel. The date or time will be printed on your pictures as displayed.

The date and time can be imprinted on photographs taken with a setting in the image zone and the shutter-priority zone.

The date LCD panel can be altered as follows by pressing the date mode button (MODE).

Year, month, day	'95 M 1 15	(1995, January 15th)
↓		
Day, hour, minute	15 16:45	(15th, 16:45)
↓		
Blank	- - - - -	(No imprinting)
↓		
Month, day, year	M 1 15 '95	(January 15th, 1995)
↓		
Day, month, year	15 M 1 '95	(15th January 1995)

- M indicates month.
- "—" indicates imprinting. When it blinks when the shutter is pressed, the date or time will be imprinted on the photograph.
- When the date LCD panel becomes dim, please change the battery (see page 44).

### Canceling the Date or Time Imprinting

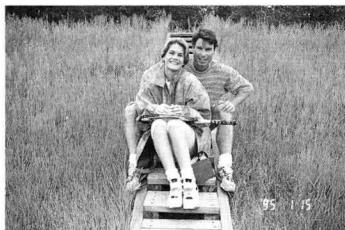

When you do not wish to imprint the date and time to your photographs, press the **MODE** button until the display panel shows “- - - - -”.

- Example of photograph with date imprinted on it.

### Changing the Date and Time

The date and time can be changed as follows.

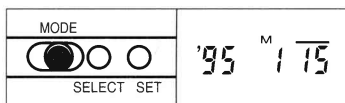

- 1 Press the **MODE** button until the display shows the day or hour which has to be changed.

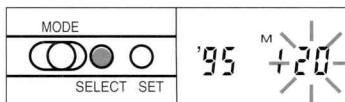

- 2 Press the **SELECT** button to select the number to be changed. The number at the selected position will then blink. Press the **SET** button to correct the entry.

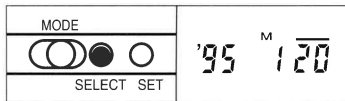

- 3 When the entry has been corrected as required, press the **SELECT** button again and the figure will stop blinking. When all the numbers have been set correctly and have stopped blinking, the date and time setting is complete.

## IV. SELF-TIMER OPERATION AND DATE IMPRINTING

### Changing the Quartz Date Back Battery

When the figures on the date LCD panel become dim, please change the battery. The battery life is about three years. The date function uses a single CR2025 lithium battery.

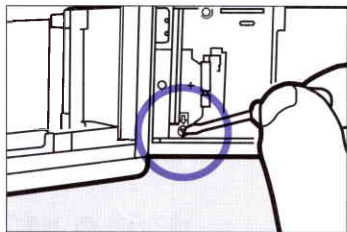

**1** Open the back cover, and remove the battery cover by loosening the screw as shown in the picture.

**2** Remove the battery.

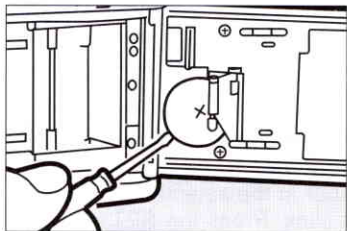

**3** Insert the new battery with the positive terminal facing up, and replace the battery cover.

**4** Reset the date and time as necessary.

## V. OPTIONAL BP-8 AA BATTERY PACK

Use the BP-8 AA Battery Pack if you want to use AA-size batteries. Both AA-size alkaline (LR6) or AA-size Ni-Cd (KR15/51) batteries can be used.



Alkaline-manganese or Ni-Cd batteries are recommended. AA-size lithium batteries should not be used as they have a high voltage level which can damage the camera's electronic circuits.

### Nomenclature

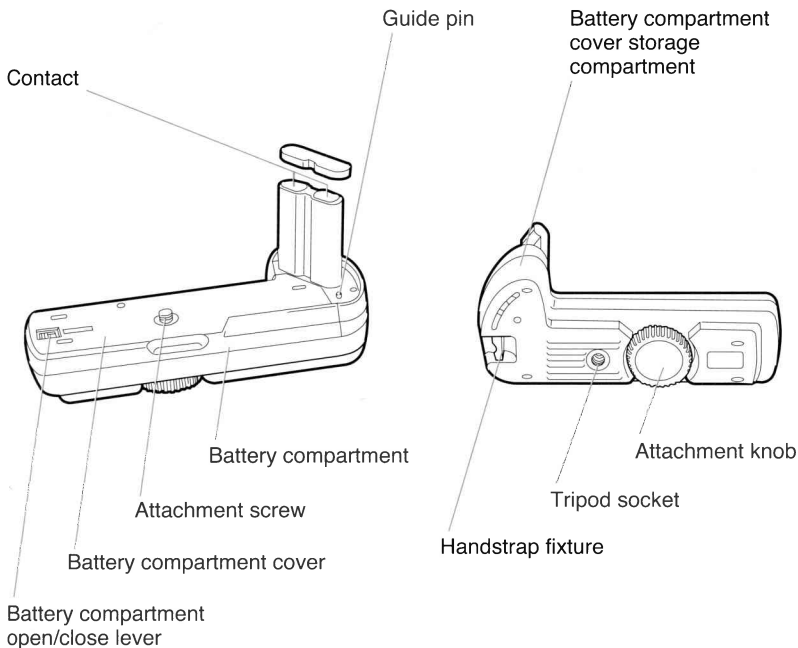

## V. OPTIONAL BP-8 AA BATTERY PACK

### Battery Installation

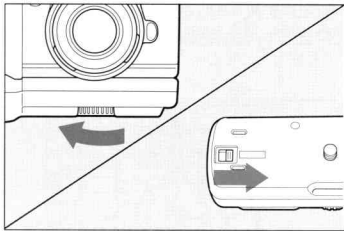

**1** Turn the attachment knob in the direction of the arrow and remove the AA Battery Pack from the camera.

**2** Slide the battery magazine lever to open and remove the battery compartment cover.

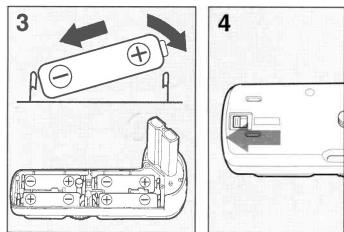

**3** Insert the batteries as indicated on the battery compartment, ensuring that the positive and negative terminals of each battery are oriented correctly.

Insert the battery's negative terminal first and slightly press the battery pack's negative contact while fitting in the battery's positive terminal.

**4** Put on the battery compartment cover and slide the battery compartment as shown by the arrow to lock the cover.

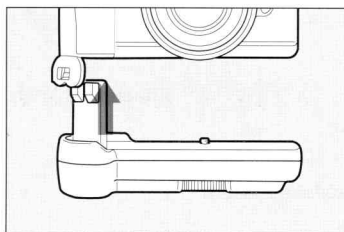

**5** The AA Battery Pack's contact unit is now housed in the camera's battery compartment. Put the camera's battery compartment cover in the storage compartment in the AA Battery Pack's battery compartment.

## V. OPTIONAL BP-8 AA BATTERY PACK

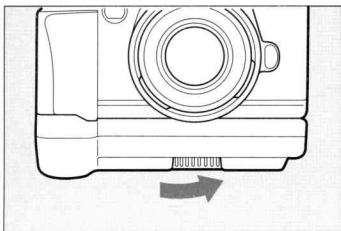

- 6** Turn the attachment knob in the direction of the arrow until it stops.

### Shooting Capacity in Rolls Using the AA Battery Pack

Temperature	Shooting Capacity (Rolls) (Without Flash)	
	AA-size alkaline-manganese batteries	AA-size Ni-Cd batteries
Normal temperature (+20°C)	100	75
Low temperature (-10°C)	5	50

- Test data based on Canon's Standard Test Method, using new batteries, a 35-80mm F4.5-5.6 III lens and 24 exposure film.
- Autofocus operation or taking shots without film will reduce the overall shooting capacity.



It is possible to remove the AA Battery Pack and use lithium batteries (CR123A/DL123A). If you use lithium batteries, please refer to page 8.



1. The AA Battery Pack is intended for use with LR6 AA-size alkaline-manganese batteries or R15/51 AA-size Ni-Cd batteries only. No other battery types should be used.
2. Do not use different battery types together in the AA Battery Pack (such as using alkaline-manganese and Ni-Cd batteries together).
3. When changing the batteries of the AA Battery Pack, change all four batteries at the same time.
4. Be sure that the positive and negative terminals are oriented correctly to prevent a short circuit.



## **VI. OTHER INFORMATION**

This section contains data to help you get the best from your camera. It contains an explanation of the basic terms used in photography, some tips on how to use the camera's various functions when taking pictures, and an introduction to some of the accessories available.

### **Correct Exposure**

To ensure correct exposure of the film installed in the camera with the light passing through the lens, the amount of light is controlled by a combination of shutter speed and aperture value. The exposure is said to be correct when the level of light reaching the film is such that the bright and dark parts of the picture is neither excessive nor insufficient.

### **Automatic Exposure (AE)**

The camera has a mechanism which automatically sets the correct exposure by controlling the aperture and shutter speed according to the brightness of the scene and according to the camera's exposure setting program. Exposure is set according to the programs for the camera's image zone and shutter-priority zone settings.

### **Shutter Speed**

The shutter in the camera body controls the length of time that the film is exposed to light. The length of time that the shutter remains open is called the shutter speed. The shutter speeds are shown on the command dial, ranging from 2000 (1/2000th of a second) to 8 (1/8th of a second), and B (bulb).

### Aperture Value

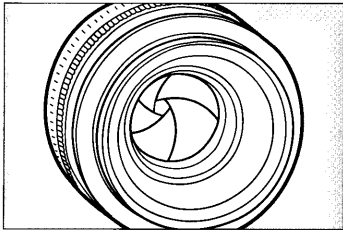

Integrated in the lens, the aperture is an opening which can be widened and narrowed to adjust the amount of light reaching the film. The size of the opening is called the aperture value. The camera displays the aperture value on the LCD panel in a range from 1.0 to 32, although this may vary depending on the lens used.

The larger the aperture value, the smaller the diameter of the aperture when the photograph is taken, resulting in less light reaching the film.

### Film Speed (ISO Number)

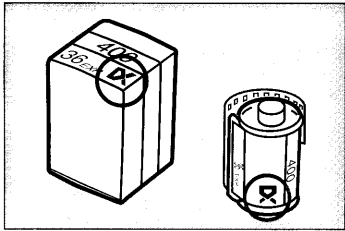

The film speed is a value indicating the level of the film's sensitivity to light, as set by the ISO (International Standardization Organization). The camera can use film with an ISO number in a range from 25-5000.

The higher the ISO number, the higher the film's sensitivity to light. The higher the film speed, the lower the lighting level required for photography. With high-speed film, pictures can be taken under low-light conditions. Film should be selected according to your photographic objectives.

## VI. OTHER INFORMATION

### Depth-of-Field

Depth-of-field is the area that is in focus in front of and behind the subject which is also in focus. When the aperture is smaller (i.e. when the aperture value is larger), the area in focus is longer, and this is called a deep depth-of-field.

Conversely, when the aperture is larger (i.e. when the aperture value is smaller), the depth-of-field becomes shallower.

Depth-of-field has the following properties.

- (1) The larger the aperture value, the deeper the depth-of-field.  
... increase the aperture value to increase the depth-of-field.
- (2) With the same aperture value, a greater depth-of-field will be obtained with a lens with a shorter focal length.  
... a wide-angle lens or the wide angle setting on your zoom lens gives greater depth-of-field.
- (3) With the same aperture value, a greater depth-of-field can be achieved by moving further away from the main subject.
- (4) When the subject is in focus, the depth-of-field will be shallower in the front and deeper behind the subject.

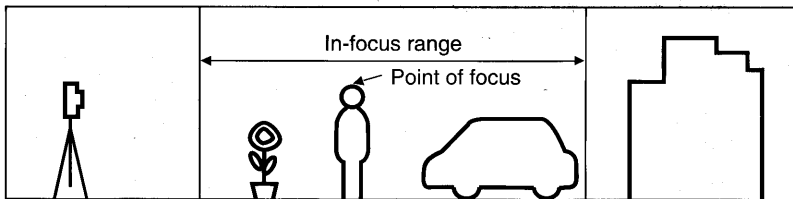







# Troubleshooting Tips

Before you start thinking that there might be something wrong with your camera, please check the following checklist. If this doesn't solve the problem, please take the camera to your nearest Canon service facility (listed at the back).

Problem	Cause	Solution	See page
1. No display on panel	Batteries exhausted.	Replace the batteries.	14
	Batteries installed incorrectly.	Install the batteries correctly.	14
2. The shutter doesn't release.	The film is not loaded correctly. (the film counter is not displayed on the LCD panel)	Reload the film correctly.	18
	There is rewound film in the camera. (film counter on the LCD panel shows the figures 00 ?)	Replace the film.	18
	The camera is not focused? (focus lamp in the viewfinder blinking)	Press the shutter button halfway again. If it still does not focus, set the focus mode switch to M (manual) and focus manually.	
3. Photographs are blurred.	Focus mode switch on M. (manual)	Set the focus mode switch to AF (Autofocus).	16
	Camera shake.	Press the shutter button without shaking the camera.	17
4. On the LCD panel, only the  is blinking.	The batteries are very low.	Replace the batteries. You can take photographs normally when the battery symbol lights.	15
	Misoperation due to some other cause.	If the shutter button is pressed halfway and the battery symbol lights, photographs may be taken normally. * If after doing the above a number of times and the battery symbol still does not light, there may be a problem with the camera. Please take it to your nearest Canon service center.	15

# Functions Usable in Combination

Command dial symbol	Autofocus		Film advance		Metering method		Built-in flash		Focusing point	
	One-shot	AI Focus	Single frame	Continuous	Evaluative metering	Partial metering	Automatic	Flash always fires	Three-point	Center-focus
		●	●		●		●		●	
	●			●	●		●		●	
	●		●		●		●		●	
	●		●		●		●			●
		●		●	●		●		●	
2000 - 8	●	●		●	●	(●)*		●	●	(●)
	●			●	●	(●)*		●	●	(●)
B		●	●		—	—		●	●	

(\*) Partial metering is only possible when the partial metering button is pressed.

**One-shot:** The exposure is set at the same time as the camera focuses the subject. The shutter can not be released until focusing is achieved.

**AI Focus:** When a subject taken with the One-shot autofocus continues to move, the movement of the subject is predicted and the AI Servo autofocus automatically adjusts.

**AI Servo:** This allows you to focus continuously on a moving subject. The exposure is set immediately before the shutter is released.

**Continuous shooting:** When the shutter is held down, one frame per second will be taken continuously.

**Evaluative metering:** This sets a suitable exposure for shots where there is a large difference between the light level of the subject and that of the background.

**Partial metering:** This ensures correct exposure of the area within the partial metering circle in the viewfinder.

# Main Accessories

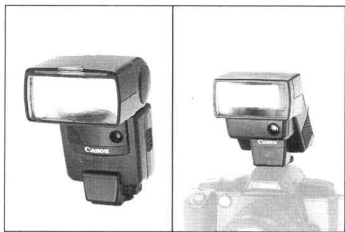

## Canon Speedlite Flashes (Sold Separately)

Speedlite flash units include the powerful 540EZ zoom flash, which clips on to the accessory shoe and has a maximum guide number of 54 at ISO 100, m, and the 300EZ, which has a maximum guide number of 9.14 at ISO 100, m.



It is recommended that you use a Canon Speedlite flash unit with your EOS camera. Particular care must be taken with flash units designed for use with cameras of other manufacturers (such as those with a hot shoe connection) and with high-current flashes and auxiliary flash units, etc. which could cause damage to your camera.



## Remote Switch RS-60E3

The RS-60E3 remote switch is attached to the camera's remote control jack and is intended for taking macro or long exposure shots (such as bulb shots) using a tripod. The special cable release prevents camera shake.



## Eye-piece Extender EP-EX15

The EP-EX15 eye-piece extender extends the EOS viewfinder viewing distance by 15 mm. Attaching the extender sets the magnification of the viewfinder to about 0.5.

## VI. OTHER INFORMATION

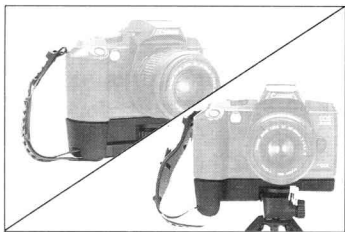

### GR-80TP Grip

The GR-80TP grip, has a hand strap attached and it, greatly increases the size of grip, making the camera easier to hold. The grip is also equipped with a simple tripod for micro photography and self-timer shots.

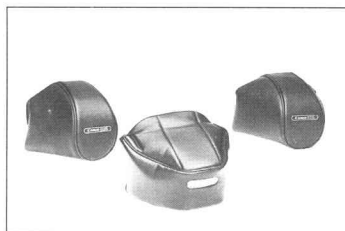

### Camera Cases

There is a semi-hard case (EH8) and a soft case (SB-5) to accommodate the camera with the lens left on, ensuring that your camera is well protected.

The soft case can also accommodate the camera with either the AA Battery Pack or the GR-80TP Grip still attached.

The following lenses can be accommodated with the camera:

- Soft Case: EF28-80mm f3.5-5.6 II USM
- EH-8-L: EF35-80mm f4-5.6 USM, EF35-105mm f4.5-5.6 USM
- EH-8-LL: EF28-80mm f3.5-5.6 II USM, EF80-200mm f4.5-5.6 USM

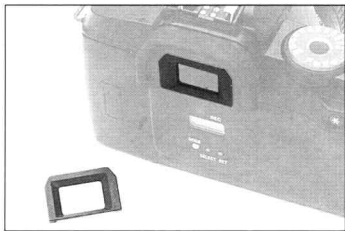

### Dioptic Adjustment Lenses

The dioptic adjustment lenses allow near or far sighted users to take photographs without having to use their eyeglasses. While the camera itself has a  $-1$  diopter, there are 10 interchangeable correction lenses available. Select the correct one for yourself by trying it out on the viewfinder.

- The numerical values printed on the dioptic lenses indicate the dioptic value when attached to the camera. This number does not indicate the dioptic value of the dioptic adjustment lens itself.



# Major Specifications

Type	35 mm focal plane shutter AF/AE SLR (single-lens reflex camera with built-in auto film winder, flash and [auto date function].)
Usable lenses	Canon EF lens series
Lens mount	Canon EF mount (electronic signal transfer system)
Viewfinder	90% vertical and horizontal coverage.
Magnification	× 0.7 (50 mm lens on infinity)
Standard diopter	-1 diopter (eyepoint 18.5 mm)
Focusing screen	Matte screen with fixed, AF frames, partial metering circle.
Shooting modes	<ol style="list-style-type: none"><li>① Shutter-priority AE (1/2000-1/8th of a second)</li><li>② Fully automatic</li><li>③ Image select function (four types)</li><li>④ Flash AE (A-TTL or TTL program flash AE with the built-in flash or a Speedlite)</li><li>⑤ Bulb</li><li>⑥ Self-timer</li></ol>
Camera shake warning	Operates in fully automatic mode and with image zone settings. AE indicator blinks when set to fully automatic and the shutter speed is 0 to 0.5 steps slower than 1/focal length of the lens in use.
Metering range	EV 2-20 (at normal temperature, 50mm f/1.4 lens with ISO 100)
Film speed setting	ISO 25-5000, automatically set according to DX code.
AF control system	<ol style="list-style-type: none"><li>① One-shot autofocus: focusing stops on completion and shutter release is enabled when focusing is achieved.</li><li>② AI Focus: One-shot autofocus, switches automatically to AI Servo.</li><li>③ Manual: with the focus mode switch on M, manual focusing is possible.</li></ol>
Effective AF range	EV 1.5-18 (ISO 100 standard chart)
AF auxiliary light	Automatically emitted.

## VI. OTHER INFORMATION

Shutter	Vertical-travel, focal plane shutter with all speeds electronically controlled.
Shutter speeds	1/2000-1/8th of a second and bulb. X-synch at 1/90 sec.
Self-timer	Electronically controlled. (with about 10 second delay)
Film Loading	Automatic. After film loading and back cover closure, the film automatically winds to the end of the roll and stops.
Film Advance	Automatic film advance: ① Single shot. ② Continuous shooting (up to a maximum of about one frame per second).
Rewind	Automatic rewind. Rewind in mid roll possible.
Built-in flash	Directly controlled, retractable automatic TTL flash above the pentaprism. ① Guide number: 12 (ISO 100 m ) ② Recycling time approx. 2 sec. ③ Flash coverage: angle of view of a 35mm lens.
Flash contacts	X-sync contact: Connected directly to the accessory shoe.
Batteries	2 lithium CR123A/DL123A batteries 4 AA-size alkaline-manganese LR6 batteries or 4 AA-size Ni-Cd R15/51 batteries (using the AA Battery Pack)
Battery level check	Can be checked by setting the command dial to any setting outside the special mode zones.
Size	145 (W) × 92 (H) × 61.9 (D) mm 147.2 (W) × 119.3 (H) × 66.3 (D) mm (AA Battery Pack kit)
Weight	355 g with the quartz date back (Body only and excluding two CR123A/DL123A lithium batteries) 450 g (with AA Battery Pack, body only, excluding four batteries)

## VI. OTHER INFORMATION

Lens		EF35 - 80 f/4 - 5.6 III	EF38 - 76 f/4.5 - 5.6
Angle of View	Diagonal	63° - 30°	60° - 32°
	Vertical	38° - 17°	34° - 18°
	Horizontal	54° - 25°	50° - 27°
Optical Construction		8 elements in 8 groups	6 elements in 6 groups
Minimum aperture		22 - 32	22 - 32
Shooting distance		0.4 m - ∞	0.58 m - ∞
Maximum magnification		35 mm	38 mm
		0.11 (228 × 352 mm)	0.08 (397 × 485 mm)
		80 mm	76 mm
		0.23 (104 × 155 mm)	0.15 (206 × 247 mm)
Size and number of filters attachable		52 mm, 1	52 mm, 1
Length × maximum diameter		63.5 × 65 mm	63.8 × 65 mm
Optimum hood		EW-54 II	EW-54
Weight		175 g	155 g

- The specifications of this product as well as some external features are subject to change without notice. (All data based on Canon's Standard Test Method)

# A Quick Guide to Function Settings

## Power source

Checking the battery level  
see page 15

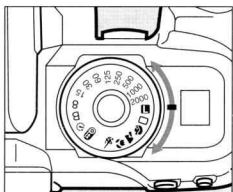

Using the AA Battery Pack  
see page 45

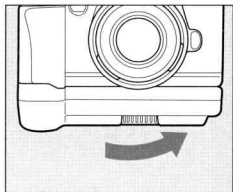
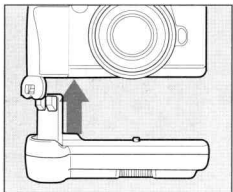

## Film

Taking continuous shots  
see page 29

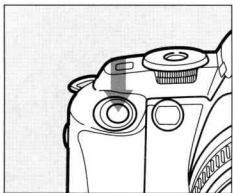

Rewinding the film in mid roll  
see page 39

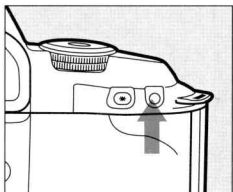
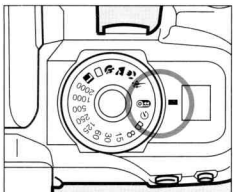

## VI. OTHER INFORMATION

### Focusing

Focusing an off-center subject  
see page 24

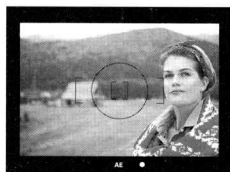

Focusing with the center AF frame  
see page 37

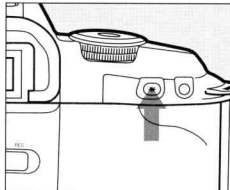

### Exposure

Taking photographs on fully automatic  
see page 21

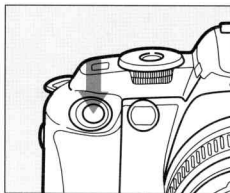
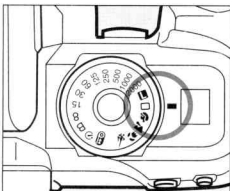

Taking photographs with the image select function



see page 25

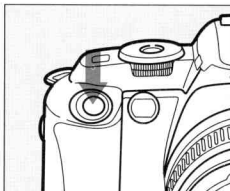
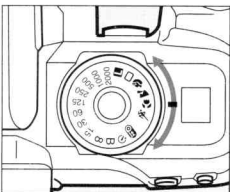

Taking photographs with the desired shutter speed  
see page 29

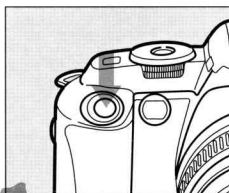
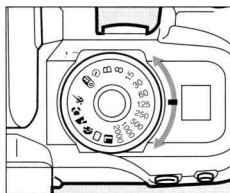

Taking photographs with the desired aperture value  
see page 32

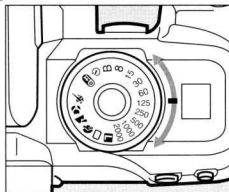
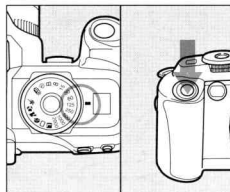

Taking photographs with fixed exposure  
see page 36

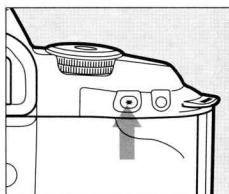
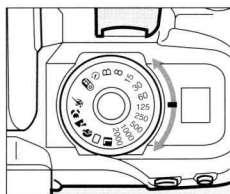

Flash photography  
see page 33

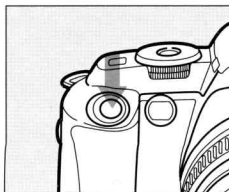
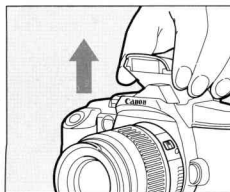

## VI. OTHER INFORMATION

Applicable shots

Bulb exposure  
see page 38

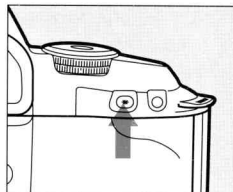
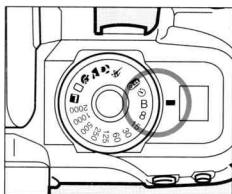

Using the self-timer  
see page 40

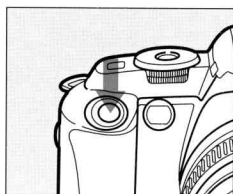
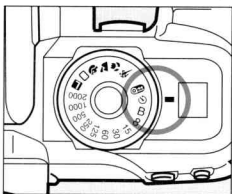

Imprinting the date and time  
see page 42

